

MCI SynAIRgPURE™

Owner's Manual

About	2
Specifications	3
Cautions & Warnings	3
Product Contents	4
Installation Hardware	4
Replacement Parts	4
Installation Tools	5
Installation Requirements	5
Installation Process	6-7
Maintenance	8
Cell Disposal	8
Changing the Cell	9
Product Options	9
DBI Cell Installation	10
Warranty	11

www.BestLivingSystems.com

800.728.7206

www.BLSWarranty.com

Welcome

Thank you for your purchase of the MCI SynAIRgPure™ Air Purification Enhancement System. This unit is designed to be installed into an existing HVAC system, and used as a virtually maintenance-free enhancement to current air purification technology.

Please read and follow all service procedures outlined in this manual.

Please record the name and phone number of your Distributor/Contractor.

Name _____

Phone #: _____

Please record the serial number of your MCI SynAIRgPure™.

Serial #: _____

About BLS HVAC

MCI SynAIRgPure™ is a new generation Air Purification Enhancement System. Designed to work with existing purification technology to reduce odors, smoke, and a broad spectrum of indoor air contaminants.

MCI SynAIRgPure™ is easily mounted into air conditioning and/or heating systems where contaminants can grow. When the HVAC system is in operation, MCI SynAIRgPure™ produces the MCI™ (Multicluster-Ionization) Process consisting of hydroperoxides, superoxide ions, and safe low level ozone, all of which are friendly oxidizers that revert back to oxygen and hydrogen after the oxidation of a pollutant. As a result, the air and surfaces will be cleaner.

Specifications

The standard MCI SynAIRgPure™ 16K uses a 9" MCI™ Cell. This cell is rated for 16,000 Cubic Feet of breathing space. (1-3 Tons HVAC System)

Up to two (2) additional DBI Cells can be added to increase the effective area up to 40,000 Cubic Feet tons of breathing space. (5-10 Tons HVAC System)

DBI Cells can be individually purchased through your Distributor/Contractor.

MCI SynAIRgPure™ 16K*	MCI SynAIRgPure™ 16K	MCI SynAIRgPure™ 24K	MCI SynAIRgPure™ 40K
Return Plenum (Keeps internal parts cleaner)	Supply Plenum 16,000 Cubic Feet 1-3 tons or 400cfm-1200cfm	Supply Plenum 24,000 Cubic Feet 3-5 tons or 1200cfm-2000cfm	Supply Plenum 40,000 Cubic Feet 5-10 tons or 2000cfm-4000cfm
Enhanced PCO	Enhanced PCO	Enhanced PCO w/single DBI Cell	Enhanced PCO w/dual DBI Cell

* NO OZONE option available. Increase this options output by adding +2 DBI Cell(s).

Cautions & Warnings



WARNING: UV Light in operation. Disconnect unit from power supply before servicing. Failure to follow warnings may result in severe eye damage.



CAUTION: To reduce the risk of shock, this equipment may have a grounding type plug with a third (grounding) pin. This plug will only fit into a grounding type power outlet. If the plug does not fit into the outlet, contact a qualified electrician or HVAC specialist to install the proper outlet. DO NOT alter the plug in any way.

Product Contents



Ballast Housing



12V DC Power Adapter



(1-2) DBI Cells
(Optional Additions)

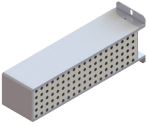

Replaceable MCI™ Cell
(Includes UV Lamp)

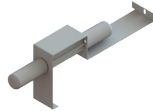

DBI Mounting Bracket
(Optional Addition)

Installation Hardware

(4) #8 - 32 Slotted Hex Machine Screw

(4) #8 - 32 Hex Machine Screw Nuts

(4) #8 - 32 Wing Nuts

Replacement Parts

Your BLS HVAC unit requires no periodic maintenance beyond the normal replacement of the MCI™ and DBI Cells on an annual basis. The Cells are working when the indicator lights are on (Sight Glass for MCI™ Cell and LED for DBI Cell). For optimal performance, annual maintenance is encouraged.

If you need a cell replacement, contact your Distributor/Contractor with one of the following part numbers:

MCI™ Cell Part #: BLS16KCELL

DBI Cell Part #: BLSAIO3CELL

Installation Tools



Utility Knife



1/8" Drill Bit



Phillips Head Screwdriver



Tin Snips



Power Drill/Driver



1/4" & 11/32 Wrench/Socket

Installation Requirements

The MCI™ Unit should be installed after the air handler in the HVAC system in the supply plenum.*

*Another MCI SynAIRgPure™ 16K is recommended in the Return Plenum for additional protection and to keep the internal parts clean.

An approximate opening of 3" W x 5" H will need to be cut into the existing duct work to install the unit properly.

Electrical Requirements

The unit comes with a 100-240V Power Adapter providing flexibility of placement. The adapter comes with a 120V plug with ground. Locate the unit within 6 ft. of a standard 120V ground outlet.

MCI SynAIRgPure™ 16K
Supply Plenum

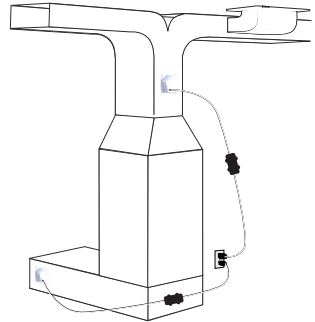

MCI SynAIRgPure™ 16K
Return Plenum (Recommended Option)



WARNING: Long term use of an extension cord is not recommended due to safety considerations.

Installation Process

1. Locate a suitable area of duct for installation.

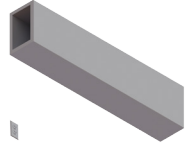

2. Cut away any insulation to expose the duct.

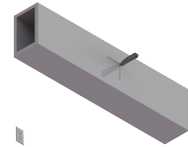

3. Draw a rectangle measuring 3" W x 5" H on the duct face. (See Template on Page 12)

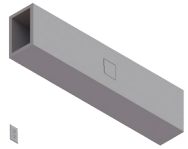

4. Use the Drill to make 4 holes in the corners of the marked rectangle.

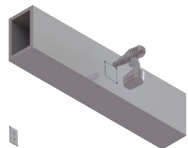

5. Use the Utility Knife or Tin Snips to cut the marked rectangle out.

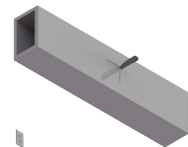

Installation Process (Cont.)

6. Place the unit through the hole and shift it up to cover any exposed hole.

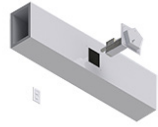

7. Mark the screw locations in the corners of the cover and remove the unit.



8. Drill the holes out and place the four (4) Threaded Bolts through the holes, from the inside, protruding out.

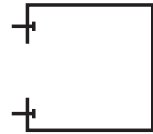

9. Place the four (4) Hex Nuts on the bolt and tighten with the aid of a wrench.

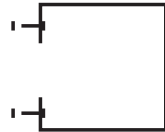

10. Place the unit through the hole and thread the remaining four (4) Wing Nuts onto the Threaded Bolts, making sure a seal is created along the backside of the Ballast Housing.

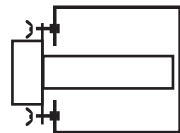

11. Plug your unit into the outlet.



Maintenance/UV Lamp Indicator

Your BLS HVAC unit requires no periodic maintenance beyond the normal replacement of the MCI™ Cell every 3 years. It is recommended, for optimum performance, that the lamp be replaced annually.

The UV Lamp Operation Indicator on the face of the unit will glow when the unit is in use. If the indicator does not glow and the unit has power, the MCI™ Cell needs replacing.

NOTE: For optimal performance, we recommend the replacement of the MCI™ Cell every 3 years and the UV Lamp annually, even if the UV Lamp appears to be operating normally. Some Mechanical Contractors, depending on contamination levels, may recommend annual replacements of lamps in conjunction with an annual servicing of your system.



UV Lamp Operation Indicator

Cell Disposal

Please do not throw a used MCI™ Cell or DBI Cell in the garbage. The special germicidal UVC bulb used in the BLS HVAC contains a very small amount of mercury. Be sure to dispose of them properly or return your used Cells to Best Living Systems for proper disposal.

Send the used cell post paid to:

Best Living Systems

1150 N. Museum Rd., Ste. 105

Conway, AR 72032

Changing the Cell

1. Unplug the unit's power cord from the outlet.



2. Remove the Wing Nuts and unit from the duct.

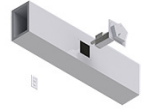

3. Remove the two (2) screws holding the cell on the rear of the Ballast Housing.

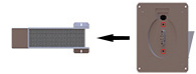

4. Replace either the UV Lamp or entire Cell with a new Cell and fasten the two (2) screws into place.

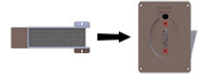

5. Replace the Unit and the Wing Nuts.



6. Plug the unit's power cord into the outlet.



DBI Cell Options

Should you need a stronger output from your MCI SynAIRgPure™ 16K we have an available option for 1 or 2 DBI (Dielectric Barrier Ionization) Cells with a mounting bracket, which will increase your effective output by 3x the normal power. (See Specifications Pg. 3 for Coverage Information)

To learn more about or to purchase the DBI Cells, contact your BLS Distributor/Contractor or visit us online @ www.BestLivingSystems.com.

DBI Cell Installation/Replacement

1. Unplug the unit's power cord from the outlet.



2. Remove the Wing Nuts and unit from the duct.

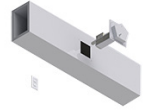

3. Remove one (1) screw holding the cell on the rear of the Ballast Housing, beneath the Molex connector.

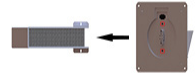

4. Place the Hook-end of the DBI Cell Mounting Bracket over the back of the MCI™ Cell, with the screw hole overlapping the open screw hole of the Ballast Housing.

NOTE: Do not cover the open cell sides.



5. Replace the screw to hold the DBI Cell Mounting Bracket in place.

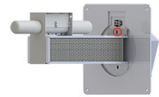

6. Place the DBI Cells by lining up to tabs and inserting them into the DBI Cell Socket. Rotate 90° to lock them into place.

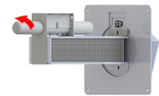

7. Plug the Cable from the DBI Cells to the connector on the rear of the Ballast Housing.

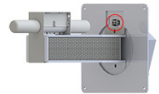

8. Replace the Unit and the Wing Nuts.

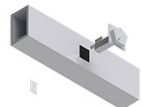

Warranty Information

Your BLS HVAC unit consists of three(3) separate products. The housing, which protrudes from the HVAC duct when installed, the MCI™ Cell which extends into the ductwork and the DBI Cell(s) (if used) which also extends into the ductwork.

Your BLS HVAC Housing (Product) is warranted to be free from all defects in material and workmanship in normal household use for a period of three (3) years from date of purchase.*

Your BLS HVAC MCI™ Cell, including the bulb, is warranted to be free from all defects in material and workmanship in normal household use for a period of one (1) year from date of purchase.

Your BLS HVAC DBI Cell is warranted to be free from all defects in material and workmanship in normal household use for a period of one (1) year from date of purchase.*

The warranty is granted only to the original purchaser. The warranty is subject to the following provisions:

Any damages or malfunctions caused by negligence, abuse, or use not in accordance with the Product Owner's Manual are not covered by this warranty. Likewise, any defects or damages caused by unauthorized service or the use of other than Genuine Best Living Systems Parts are not covered.

Best Living Systems will, at its option, repair or replace a defective Product or part(s) for the Product that is/are covered by this warranty. As a matter of warranty policy, Best Living Systems will not refund the customer's purchase price.

* Best Living Systems also provides, at an additional charge, a 5 year warranty on the housing and includes, as added value, a substantial discount for the replacement cell and bulbs that may be needed during the warranty period. For more information on the BLS Enhanced Warranty, please go to www.BLSWarranty.com or call 855.855.6070.

OBTAINING WARRANTY SERVICE

To obtain warranty service you must return the defective product along with proof of purchase to the Best Living Systems Authorized Service Center. All shipping costs submitted under this Warranty shall be borne by purchaser. Unless this Warranty is expressly renewed or extended by Best Living Systems, any repaired or replaced part of unit shall be warranted to the original purchaser only for the length of the unexpired portion of the original warranty. For the location of the nearest Best Living Systems Authorized Service Center or for other service information, please visit us online at:

www.BestLivingSystems.com/service

Before any product is sent for service, the customer should contact the Best Living Systems Authorized Service Center to obtain a Return Merchandise Authorization (RMA) Number. This RMA Number should be clearly written on the box before shipping. All components/parts including the remote (if applicable), manuals, and original packaging should be included in the return if available.

FURTHER LIMITATIONS AND EXCLUSIONS ARE AS FOLLOWS

Any warranty that may be implied in connection with your purchase or use of the Product, including any warranty of merchantability or any warranty for Fitness For A Particular Purpose is limited to the duration of this warranty. Some states do not allow limitations on how long an implied warranty lasts, so the above limitations may not apply to you. Your relief for the breach of this warranty is limited to the relief expressly provided above. In no event shall Best Living Systems be liable for any consequential or incidental damages you may incur in connection with your purchase or use of the Product. Some states do not allow the exclusion or limitation of incidental or consequential damages, so the above limitation or exclusion may not apply to you.

This Warranty gives you specific legal rights, and you may also have other rights which vary from state to state.

REGISTRATION

Please register your Product within 10 days of purchase by visiting www.BLSWarranty.com, call 855.855.6070 and consider the BLS Enhanced Warranty to insure the proper performance and maintenance of your product. The BLS Enhanced Warranty also extends the life of the warranty. Registering your new Best Living Systems product entitles you to the most up-to-date Best Living Systems warranty and promotion information.

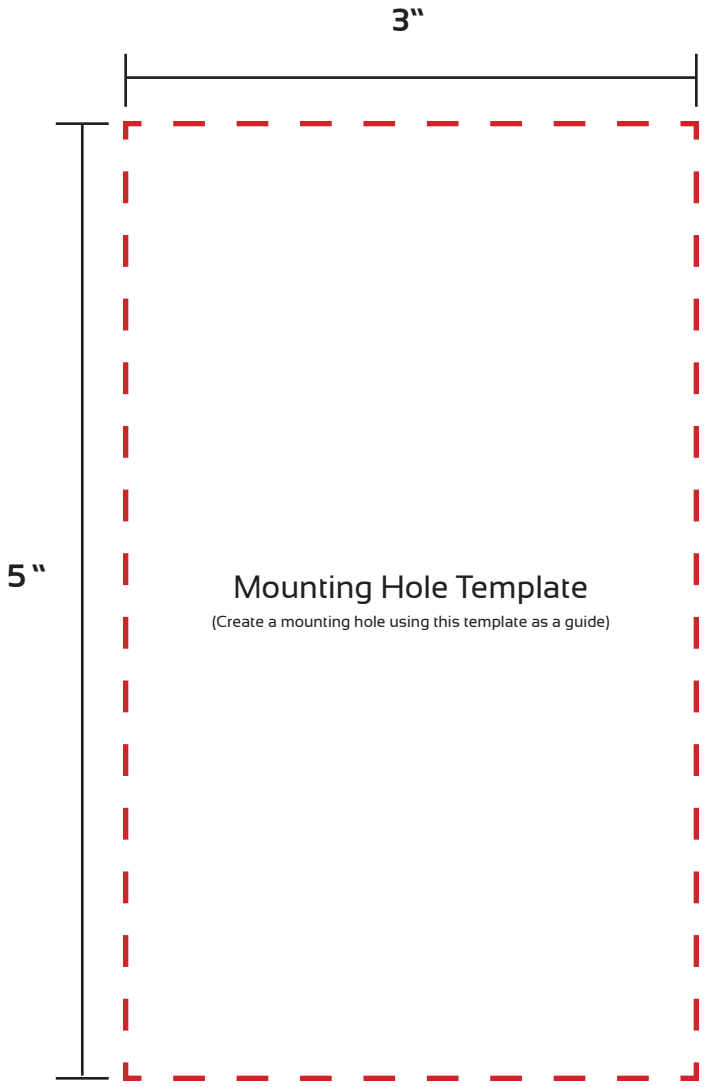

www.BestLivingSystems.com

800.728.7206

www.BLSWarranty.com